

Reliable Power for



The Commitment Company

MINING

ISO 9001-2008 Certified

Mining, a vital part of industry that truly functions on reliable power. This sector of industry, on a world-wide scope depends on power to harness natural resources such as aggregates, precious metals, iron ore, oil, gas and coal. All the machinery involved in this process uses power, in vast amounts from start to finish. Both surface and underground mining operations use power to extract minerals and load trucks. This industry uses a tremendous amount of "power" to get the job done.

The role of a transformer in this industry is at the heart of operation, converting distribution voltage into utilization voltage for operations at the load center. Since the transformer is one of the most critical elements of operation, it must meet many requirements in safety, reliability and efficiency. The mining industry "works" on power, and the transformer is the source of power for many different areas.

Load losses are of great importance as well. Virginia Transformer prides itself in designing a more efficient transformer to reduce losses and costs. In addition, this industry exists in very harsh environments surrounded by dust dirt, chemicals, moisture and airborne contaminants. This not only (potentially) effects the performance of the transformer internally, but external protection is a major consideration as well. VTC offers paint systems made to protect a unit based on its environment.

After all, Virginia Transformer got it's start providing power for the underground mining industry nearly 40 years ago.

There are different uses for transformers in the mining industry, so both liquid-filled and dry type are used. Depending on the application, there are some performance advantages that have been accepted.

Liquid-Filled units have a greater overload capacity, are better at reducing hot-spot coil temperatures and because of their thermal dissipation, have lower losses.

Dry Type transformers are usually used for lower ratings and they are usually used indoors. Dry types generally are enclosed with louvers or are sealed. These use almost no flammable materials, so pose no fire hazard when used in coal and other mines.

Virginia Transformer also offers TENV (Totally Enclosed, Non-Ventilated Dry Type) transformers, and for indoor operation supplies Dry Type up to 5000 kV.

Virginia Transformer Corp has the engineering expertise and refined manufacturing processes to build some of the most dependable, long lasting units available. For the mining industry, VTC offers transformers for drag lines, blast hole drilling and shovels (mil 167).

All of VTC's transformers are custom built to client specifications. VTC builds both liquid-filled and dry type transformers as well from 300 KVA – 300 MVA.

For over 40 years now, VTC has been making custom-built power transformers. Our history in specialty design laid the foundation for a solid engineering based company specializing in transformer and reactor solutions for industrial, commercial and utility applications.

The *NEW* Virginia Transformer now operates 3 manufacturing facilities in North America to service our global markets. Our success comes not only through our dedication to producing a top quality product, but equally through innovations in our processes driving us to the forefront of our markets.



Corporate Office
220 Glade View Drive
Roanoke, VA 24012
540.345.9892

3770 Poleline Road
Pocatello, ID 83201
208.238.0720

Compejo Industrial Chihuahua,
Ave. Homero #3307
Chihuahua, Mexico
52.614.481.4900

www.vatransformer.com

"The Commitment Company"



FACILITY LOCATIONS

Chihuahua, Chih., Mexico
Dry Type, Liquid
10 MVA/69 kV

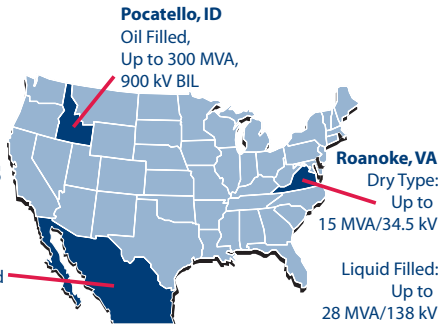

HISTORY

- 1971 – VTC established
- 1982 – Current president assumes management
- 1989 – Manufactures first LTC transformer
- 1995 – Opened 2nd manufacturing facility in Chihuahua, Mexico
- 1997 – First achieves ISO 9001 certification
- 2003 – Acquired power transformer facility, Pocatello, Idaho
- 2005 – Testing facilities upgraded enabling “front of wave” and “switching surge” tests
- 2009 – Addition of Vapor Phase Drying
- 2011 – VTC’s 40th Anniversary



MARKET REPRESENTATION

Virginia Transformer Corp uses a network of knowledgeable independent Manufacturers Representatives to support and create the best experience for our customers. These representatives augment our team of Sales Engineers and Application Engineers who work with clients to provide the best solution for their application.

ADDITIONAL SPECIAL APPLICATION TRANSFORMERS

- Three Phase Voltage Regulator
- Single Phase Transformer
- Zig Zag Grounding Transformer
- Scott Tee Connected (Converts 3 phase to 2 phase)
- Load Tap Changing
- Autotransformer
- Multi-Winding Secondary/Drive Duty/Rectifier
- “Green” Transformers (Ultra High Efficiency)
- Large Specialty Pad Mount
- Drive Isolation Transformers (18/24/36 Pulse Available)
- Variable Speed Drives Transformers
- Up to 20,000 horse power for AC and DC motors

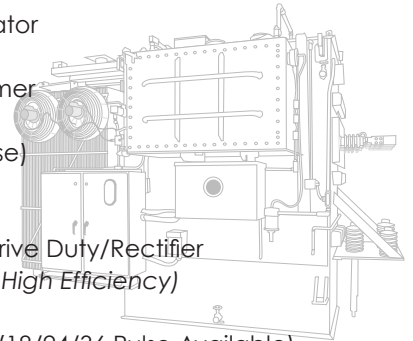

VT MINING PROJECTS

- ◆ KINCROSS GOLD 7 MVA, 69 kV
Round Mountain Gold Mine
- ◆ MINING CONTROLS 10 MVA, 34.5 kV
ICG Viper Mine
- ◆ JIM WALTER RESOURCES 7.5 MVA, 138 kV
Blue Creek Coal Mine #4
- ◆ JIM WALTER RESOURCES 2616 liquid filled rectifier duty
Blue Creek Coal Mine #7
- ◆ INMAN COAL 10 MVA, 69 kV
Indian Creek Project
- ◆ LINE POWER MANUFACTURING 10 MVA, 69 kV
Rochelle Mine
- ◆ ROUND MOUNTAIN 7.5 MVA, 69 kV
Round Mtn., NV
- ◆ PERFORMANCE COAL 5 MVA, 15 kV
Whitesville, WV
- ◆ LINE POWER MANUFACTURING 5 MVA, 15 kV
Bristol, VA
- ◆ GATEWAY ENERGY & COKE 7.5 MVA, 69 kV
Granite City, IL
- ◆ BLACK WARRIOR 7.5 MVA, 115 kV
Brookwood, AL

WHAT VTC DOES

Providing successful solutions means having the right selection of products. VTC offers a wide range of products, and the ability to customize each one to meet specific needs. VTC meets demanding system requirements such as space constraint, special voltage configurations and tough environmental conditions. Our ability to exceed these needs has gained VTC a solid reputation in supplying power transformers.

Providing High quality, long life units starts with our engineering strength. VTC boasts over 15,000 customizable designs to provide built to spec transformers for our clients for just about every application possible. Our team of application and sales engineers starts our process by reviewing technical specifications and establishing with our customers an optimum solution. From there our Electrical, Mechanical and Control Design Engineers utilize the latest tools to provide drawing packages in the industries shortest lead time.

The experience of our team and the automation of our processes set VTC apart as solution based manufacturer of all transformer needs. We are able to develop the best design for each individual need. We look at all the details of the transformer design to assure electrical and magnetic performance to optimize every phase of production.